

Master Aircraft Maintenance with the Comprehensive Amt Aircraft Mechanic Textbook Study Guide

Become a Certified Aircraft Mechanic with Confidence

Are you aspiring to join the ranks of highly skilled aircraft mechanics who ensure the safety and reliability of our skies? The Federal Aviation Administration (FAA) certification exam is the gateway to this rewarding career, and the Amt Aircraft Mechanic Textbook Study Guide is your essential companion on this journey.

This all-encompassing study guide is meticulously crafted to provide a comprehensive overview of the core knowledge and skills required for the AMT certification exam. With its clear and concise explanations, numerous practice questions, and insightful guidance, it empowers you to approach the exam with confidence and achieve success.



Aviation Maintenance Technician Handbook – General: FAA-H-8083-30A (Black & White): (AMT Aircraft Mechanic Textbook & Study Guide) by Julie Mulhern

★★★★☆ 4.7 out of 5

Language : English

File size : 74147 KB

Screen Reader: Supported

Print length : 696 pages

Lending : Enabled

FREE

DOWNLOAD E-BOOK



Unveiling the Secrets of Aircraft Maintenance

The Amt Aircraft Mechanic Textbook Study Guide delves into the intricate workings of aircraft systems, covering essential topics such as:

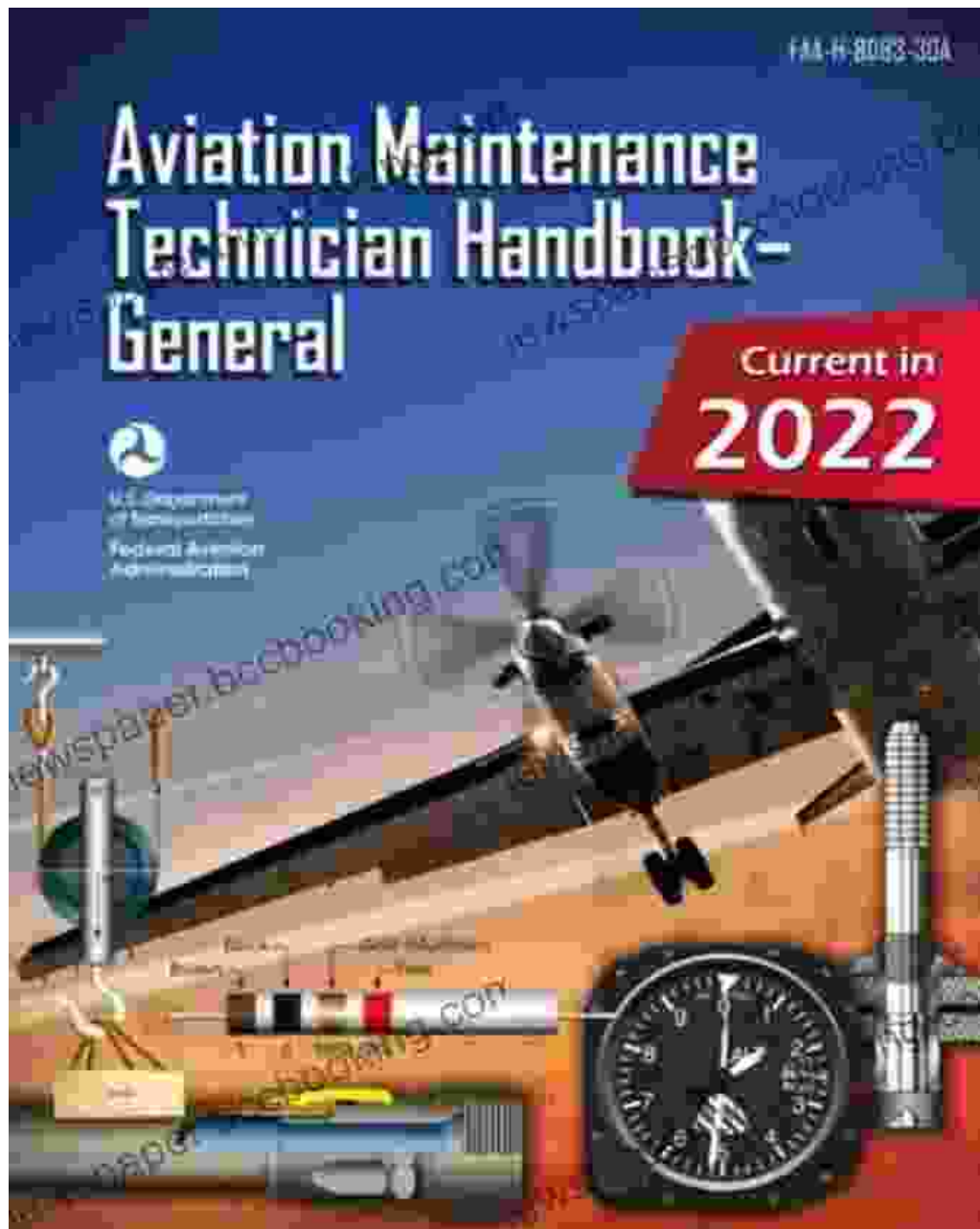

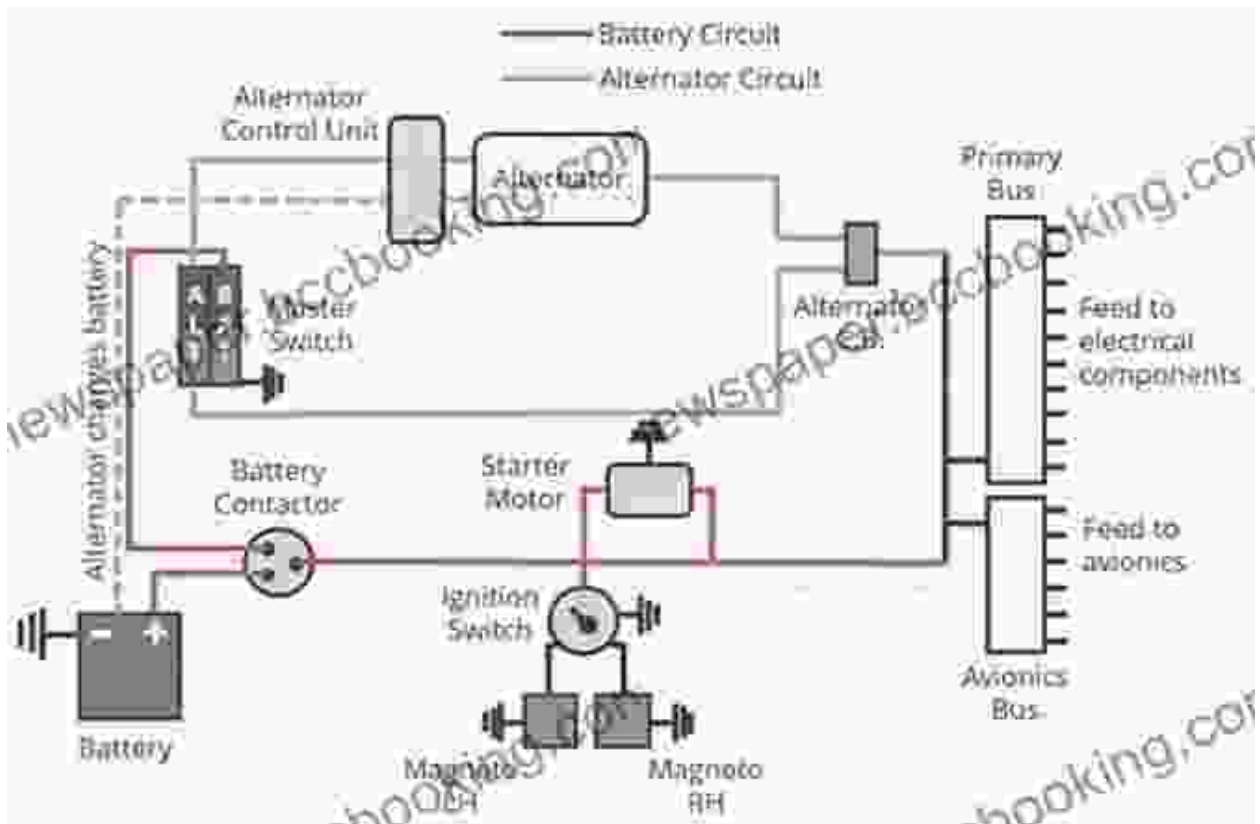

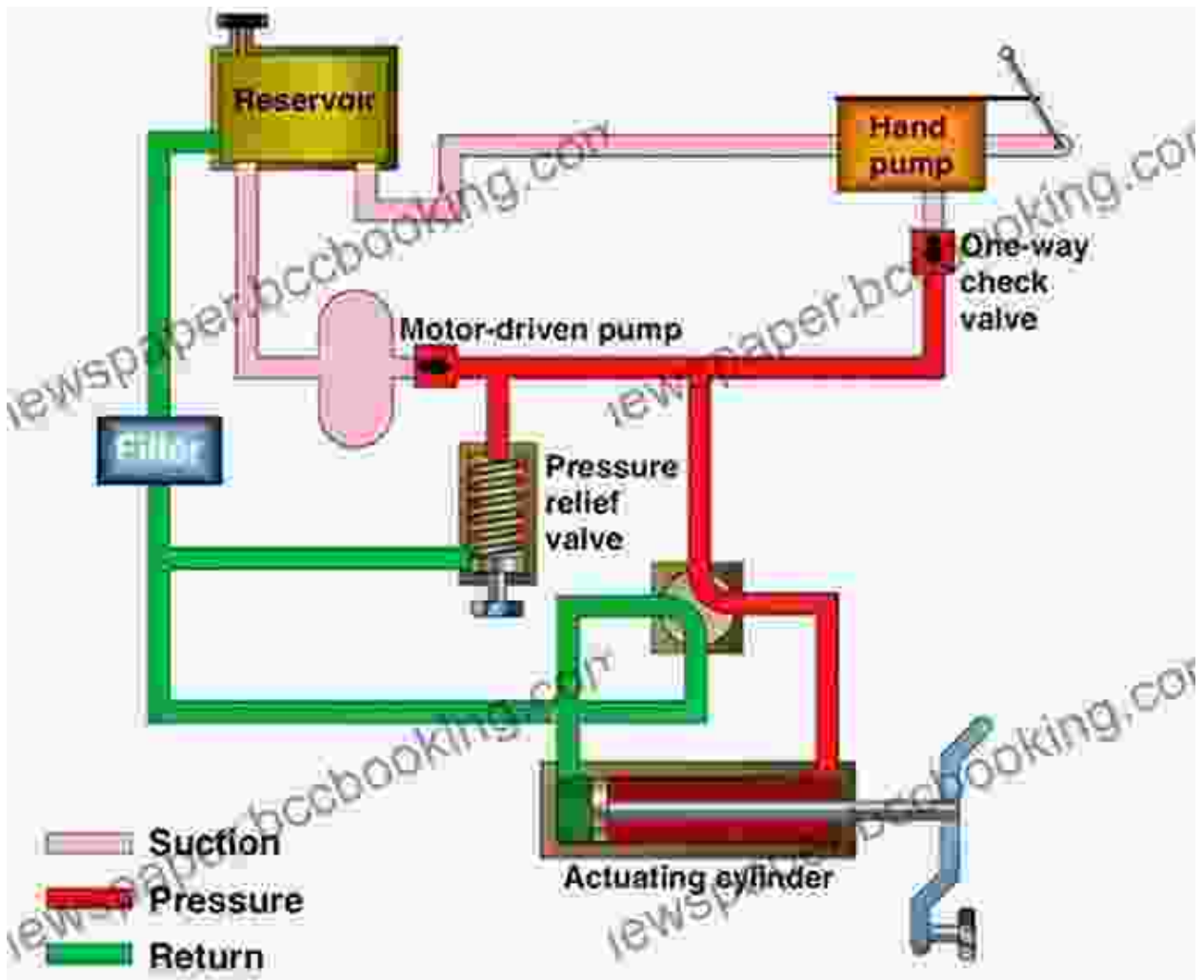

FRC Pneumatic System Layout

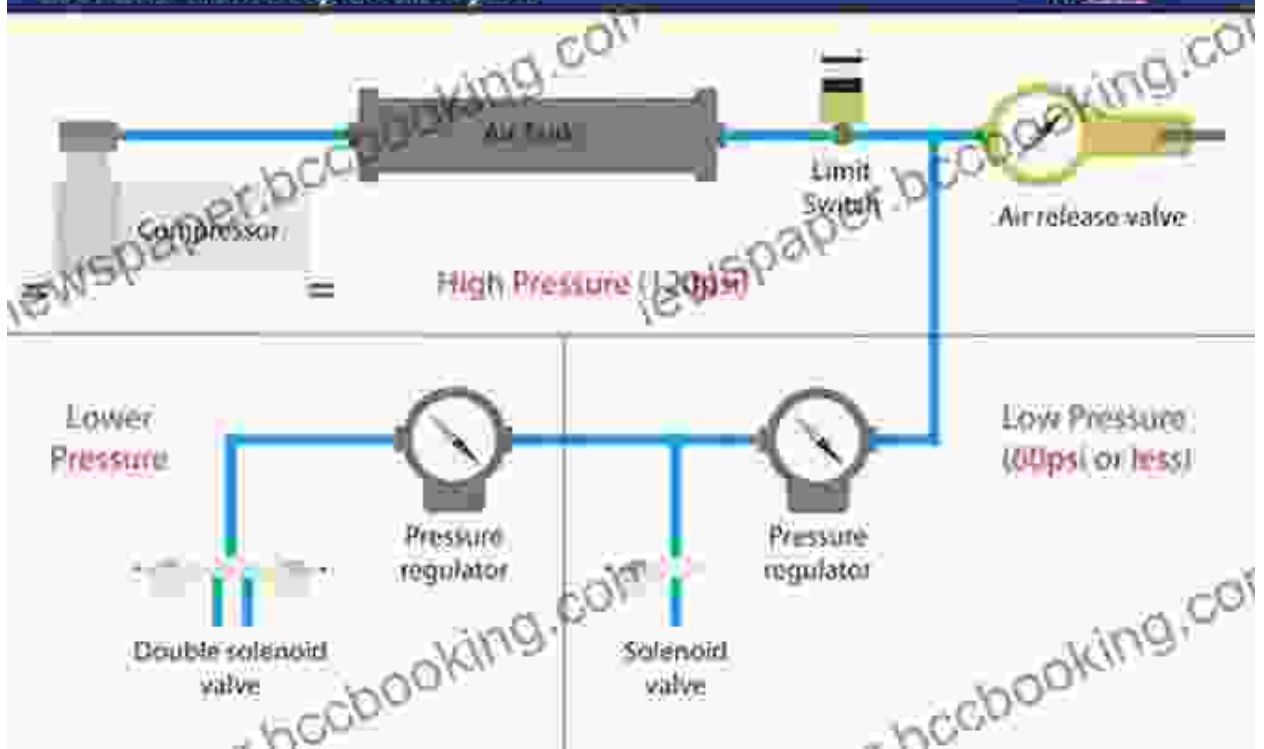



FAA-H-8083-30A

Aviation Maintenance Technician Handbook - General



U.S. Department of Transportation
Federal Aviation Administration



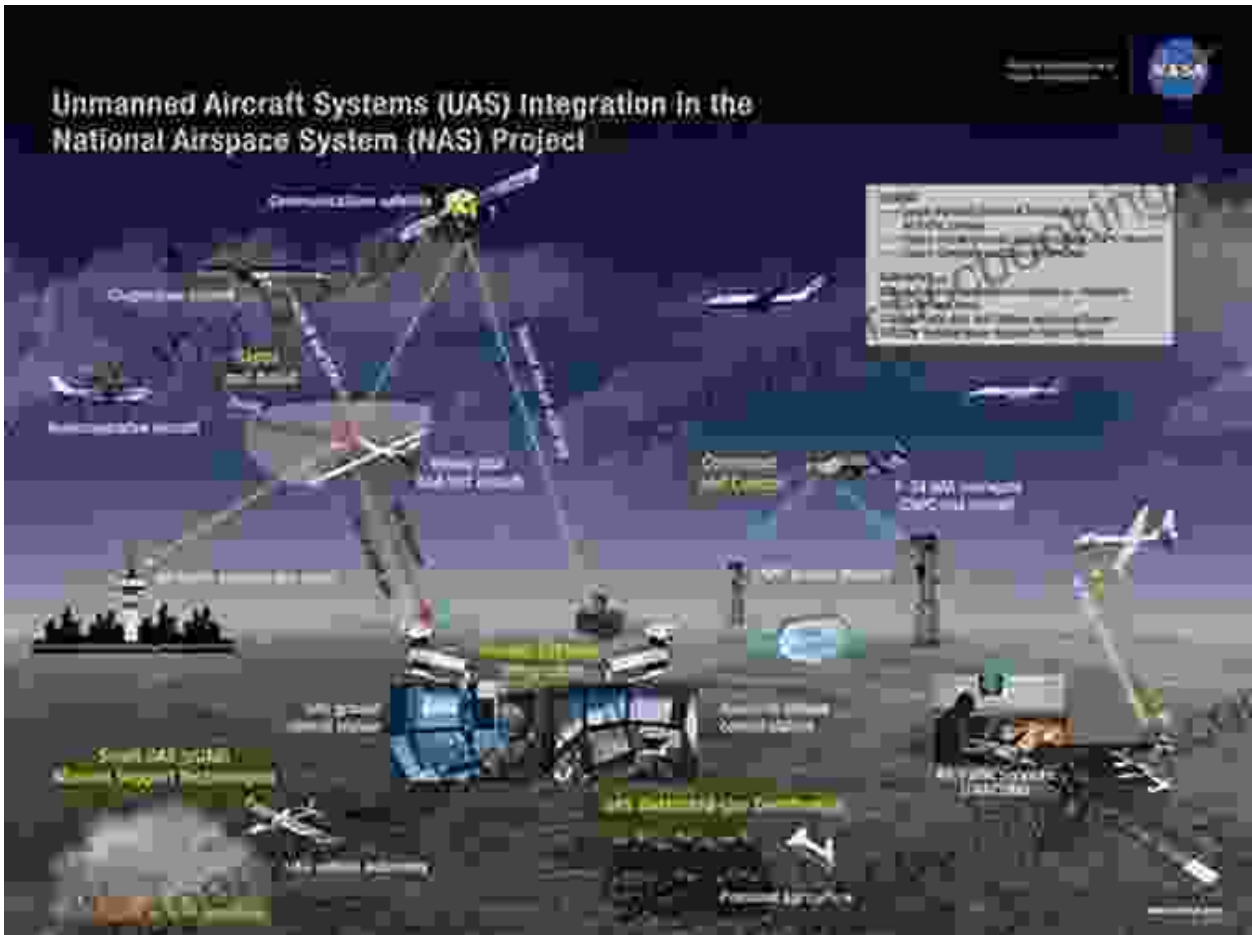

Sharpen Your Skills with Practice and Guidance

Beyond comprehensive theory, the Amt Aircraft Mechanic Textbook Study Guide provides invaluable practice materials to reinforce your understanding and prepare you for the exam. Practice questions mirror the actual exam format, challenging you to apply your knowledge and identify areas for improvement.

Expert guidance throughout the study guide provides valuable insights, shortcuts, and memorization techniques. These tips and tricks distill years of experience and help you retain information more effectively and enhance your exam preparedness.

Benefits of the Amt Aircraft Mechanic Textbook Study Guide

Investing in the Amt Aircraft Mechanic Textbook Study Guide offers a multitude of benefits, including:

- **Comprehensive Coverage:** Covers all essential topics for the AMT certification exam.
- **Clear and Concise Explanations:** Simplifies complex concepts for easy understanding.
- **Numerous Practice Questions:** Provides realistic exam preparation and identifies areas for improvement.
- **Expert Guidance:** Offers valuable tips, tricks, and memorization techniques.
- **Builds Confidence:** Empowers you to approach the exam with confidence and achieve success.
- **Career Advancement:** Positions you for a rewarding career as a certified aircraft mechanic.

Free Download Your Copy Today and Soar to Success

Take the first step towards your aircraft maintenance career. Free Download your copy of the Amt Aircraft Mechanic Textbook Study Guide today and unlock the knowledge and skills to excel in this exciting field. Join the ranks of highly skilled aircraft mechanics and contribute to the safety and reliability of aviation.

Free Download Now

Don't let a lack of preparation hinder your dreams. Invest in the Amt Aircraft Mechanic Textbook Study Guide and soar to success as a certified aircraft mechanic.



Aviation Maintenance Technician Handbook – General: FAA-H-8083-30A (Black & White): (AMT Aircraft Mechanic Textbook & Study Guide) by Julie Mulhern

★ ★ ★ ★ ☆ 4.7 out of 5

Language : English

File size : 74147 KB

Screen Reader: Supported

Print length : 696 pages

Lending : Enabled

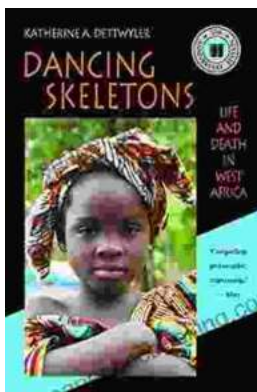

Life and Death in West Africa: A Groundbreaking Account of the Region's Tumultuous 20th Century

A Journey Through Decades of Strife and Resilience In "Life and Death in West Africa: The 20th Anniversary Edition," Pulitzer Prize-winning...

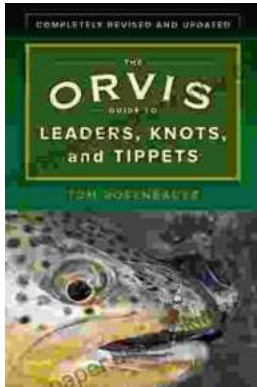

Master the Art of Fly Fishing Line Management: A Comprehensive Guide to Leader Construction and Knots

Are you an avid fly fisher who wants to take your skills to the next level?
Do you struggle with managing your fly fishing line, leading to missed...